

SPEAR 3 DC Magnet Power Supplies – An Overview*

P. Bellomo, M. Berndt, A. de Lira, G. Leyh, J.J. Lipari,
Stanford Linear Accelerator Center, Stanford University, Stanford Ca 94309
and
F. Rafael, M. Widmeyer
Stanford Synchrotron Radiation Laboratory, SLAC, Stanford University,
Stanford Ca 94309

*Presented at 3rd Asian Particle Accelerator Conference
(APAC 2004), 3/22/2004—3/26/2004,
Gyeongju, Korea*

* Work supported by Department of Energy contract DE-AC03-76SF00515.

SPEAR 3 DC MAGNET POWER SUPPLIES – AN OVERVIEW*

P. Bellomo, M. Berndt, A. de Lira**, G. Leyh, J.J. Lipari (SLAC)
 F. Rafael, M. Widmeyer, (SSRL)
 Menlo Park, CA 94025-7015, USA

Abstract

The Stanford Synchrotron Radiation Laboratory (SSRL) has successfully commissioned SPEAR 3, its newly upgraded 3-GeV synchrotron light source. First stored beam occurred December 15, 2003. This paper presents an overview and descriptions of the DC magnet power supplies. These consist of tightly-regulated (≤ 10 ppm) current sources ranging in output from 30 A to 800 A and output power ranging from a few watts to almost 1.0 MW. A total of 226 magnet power supplies are in successful operation. The SPEAR 3 upgrade performance and reliability requirements mandated new power supplies for both the SPEAR 3 storage ring, and for the booster-to-SPEAR 3 (BTS) transport line. A large variety of precise, highly stable current power supplies were needed to fill the diverse magnet needs. Also described are outside procurement aspects, in-house construction, installation, testing, performance and operation of the power supplies. During field testing, special emphasis was made to ensure a critically damped response on the current loop. Frequency spectra measurements were made for reference and future diagnostics.

1 INTRODUCTION

The Stanford Synchrotron Radiation Laboratory (SSRL) [1] has successfully commissioned SPEAR 3, its newly upgraded 3 GeV synchrotron light source. First stored beam occurred December 15, 2003. A 100mA beam was stored on January 20, 2004 [2].

The Power Conversion Department (PCD) [3] at the Stanford Linear Accelerator Center (SLAC) [4] was responsible for defining the Power Supply (PS) topology, and operating requirements, as well as working on the procurement process, in-house construction, pre-installation testing, installation, and commissioning of the PS. On-site installation of the PS began mid-2003. Testing started in November and was finished by mid-December. Table 1 summarizes the characteristics of the main PS.

2 DC MAGNET POWER SUPPLY OVERVIEW

Except for the correctors, all PS systems have a 10-Hz current loop control bandwidth. This is sufficient to correct the slow magnet resistance variations due to temperature changes.

The PS voltage loops have a 3dB small signal bandwidth greater than 1 kHz, which is enough to compensate for input line changes and transients.

Magnet	Volts	Amps	PS Qty
BTS Line			
Septum	50	300	1
Dipole Bend	45	500	4
Quadrupoles	80	60	2
Storage Ring			
Dipole Bend	1200	800	1
Quad Strings	700	100	4
Quadrupole singles	100	100	44
Sextupole strings	600	225	2
Correctors H & V	+/- 50	+/- 30	108
Insertion device/other trims	+/- 50	+/- 30	42
Titanium sublimation pumps	40	60	4

Table 1: Ratings on some of the SPEAR 3 Power Supplies

Based on the success of several hundred PS in operation at PEP-II [5], SSRL/SLAC mutually determined the SPEAR 3 DC magnet PS would use similar specifications whenever possible. A modern design and common components would also improve the mean time to repair (MTTR) [6, 7, 8].

2.1 Power Supplies – Control and Interface

All PS use a Bitbus [9] controller for interface, control, and output current regulation. See Fig. 1 for details. The exceptions are the bipolar output PS. These use a newly-developed Ethernet-based controller only briefly described here.

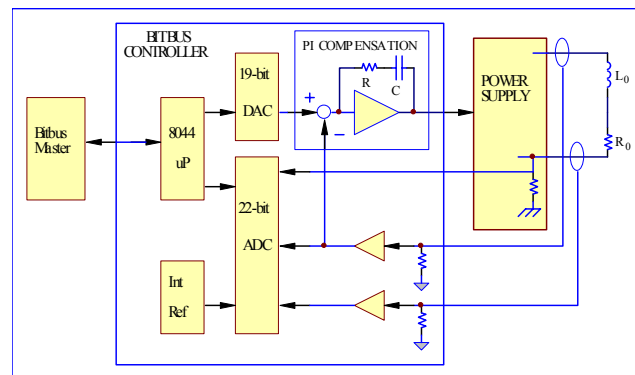

Figure 1: Basic Topology for Bitbus-Controlled PS

* Work supported by the U.S. Department of Energy under contract DE-AC03-76SF00515.

** delira@slac.stanford.edu

Internally regulated Bitbus-controlled PS operate as 500-ppm voltage sources. An external, precise, and accurate Bitbus control loop applies a programming reference to the PS for desired output current. Definition of the current loop parameters are determined by the desired 10Hz 3dB current loop control bandwidth and measurements of the PS voltage gain, and both load inductance and resistance during field testing.

All PS systems are equipped with latched interlocks to detect both PS and magnet abnormal conditions, such as: input voltage out of the range, transformer input current imbalance, internal over-temperature, ground fault, and magnet over-temperature or cooling-water flow loss. Programmable logic controllers (PLCs) sum the external interlocks. The Bitbus controller receives the summary of external interlock information and turns the PS off under abnormal conditions.

3 INTERMEDIATE POWER SUPPLIES

Sixty-nine (69) Intermediate-power (2.4kW to 22.5kW, rack-mounted) PS are in operation at SPEAR 3. Fig. 2 shows their basic topology.

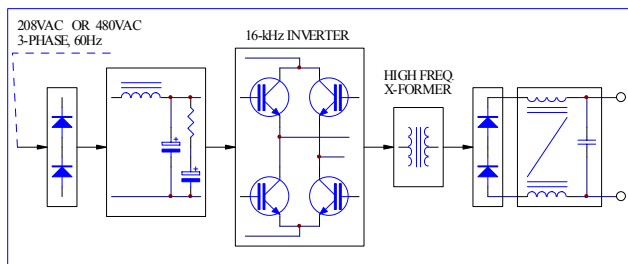

Figure 2: Intermediate PS Basic Power Topology

The Intermediate PS are off-line, 16-kHz H-bridge inverter switch-mode power supplies driving a step down class H (220°C) transformer followed by a high-frequency rectifier stage and two -40dB/decade low-pass filters. Units with a 2.4kW power rating are 208VAC, 3-phase input, with efficiencies greater than 85%. All other larger units are 480VAC, 3-phase with efficiencies greater than 90%. The voltage control loop has a 1 kHz small signal 3dB bandwidth.

SSRL/SLAC jointly specified [10] the minimum requirements, the topology and required performance, as well as the details on the interface with the control system. A 20-year of continuous-operating lifetime was specified. In order to simulate the effects of transportation to the final site, every first article of each power rating was subjected to a 1 hour, non-operating sinusoidal vibration sweep from 10Hz to 100Hz at 2G.

A 19" standard rack mounted modular design was the best option for the Intermediate PS. This allowed operation of a PS similar to the PEP-II PS, thus reducing the required inventory of spare units. They were designed to be series-connectable, thus keeping a rack-mounted modular design up to about 45kW of output. All Intermediate PS are air cooled.

During the procurement cycle, several manufacturers participated in the bidding process. Technical and cost considerations dictated manufacturer selection. Before fabrication authorization, the selected manufacturer conducted a design review with SSRL/SLAC representatives. All outstanding issues were resolved as a prerequisite for fabrication release. Delivery of the units began in March 2003 and ended in August 2003.

PCD internally inspected every PS for loose mechanical and electrical connections upon arrival. PCD then tested every PS as an integral part of the destination system with appropriate interface controls. The manufacturer made long-term (24-hour) current stability and component temperature rise tests at the factory on one PS of each voltage/current rating. PCD repeated these tests on-site.

4 LARGE POWER SUPPLIES

Six Large PS (LGPS, 70kW and 135kW) are in operation at SPEAR 3. These are enclosed free-standing units that power quadrupole and sextupole magnet strings.

SSRL/SLAC defined the basic topology [11], as seen in Fig. 3. The same Intermediate PS manufacturer also fabricated the LGPS. The basic scheme is a series combination of two phase-shifted buck converters, each one powered by the secondary of a Δ / Δ -Y line transformer. This allows for 12-pulse rectification that virtually eliminates 5th and 7th line harmonics and reduces incoming line distortion. Two cascaded LC filters that each yield an effective -40dB/decade of ripple attenuation follow the two alternating-switched buck converters.

Four 70kW LGPS are air-cooled. Two 135kW LGPS are water-cooled. Power for all 6 LGPS is 480VAC, 3-phase. Power factor is better than 0.9 and operating efficiency is greater than 90%. Like the Intermediate PS, there is a requirement for a 1-kHz small signal 3dB bandwidth on the voltage control loop. PCD added local control making it possible to operate the LGPS without the Bitbus interface to reduce the MTTR. SLAC specified seismic criteria in the structural design to minimize damage and hazards during earthquakes.

When the LGPS arrived at SLAC they underwent extensive inspection. PCD added common-mode noise-reduction input and output line filters to bring the LGPS into conformance with EMC requirements.

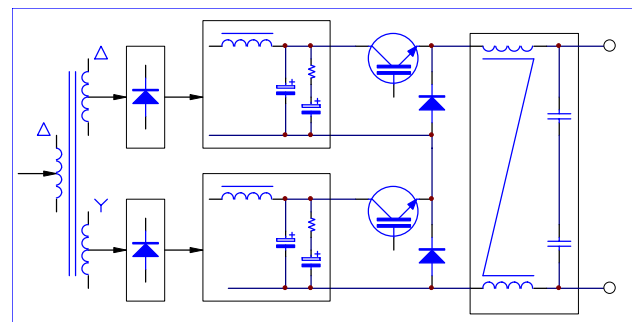

Figure 3: LGPS Basic Power Topology

5 DIPOLE POWER SUPPLY

This is the largest DC magnet PS in operation at SPEAR 3. The total power is 1.0MW with a maximum current of 800A. It furnishes tightly-regulated current for 36 series-connected main dipole bend magnets. Because PCD did not receive technically responsive proposals, PCD designed and assembled it [12] based on existing PS that power the large PEP string magnets. In this way, SPEAR 3 benefited from an existing design [8].

As seen in Fig. 4, this PS has a pre-regulation 12-pulse SCR Bulk PS stage. A local manufacturer fabricated the 12-pulse SCR rectifier/filter/bulk PS in accordance with SLAC prints. High-frequency phase-shifted chopper stages (buck regulators) follow to provide for fast response. A careful design of the chopper modules allows for a compact assembly. The Bulk PS provides an unregulated output of $\pm 650\text{VDC}$ to 4 series/parallel connected choppers, each rated for an output of 600VDC, 400A. This array of 20 kHz choppers provide an 80 kHz output of 1200V at 800A with the midpoint grounded.

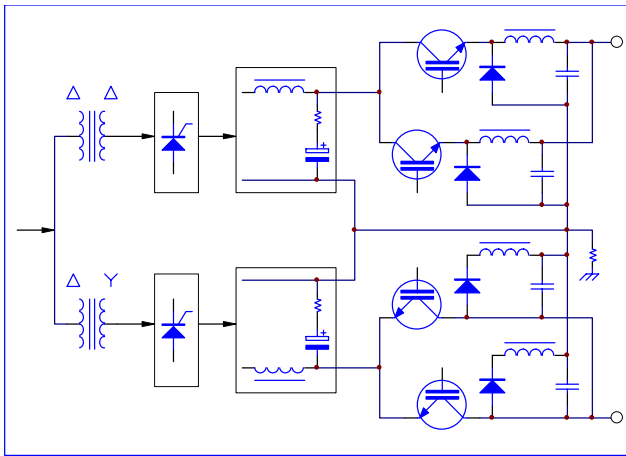

Figure 4: Dipole PS Basic Power Topology

6 BIPOLAR POWER SUPPLIES

SPEAR 3 required fast correctors for a beam-based alignment and diagnostic system. The MCOR30 modular corrector drivers provide $\pm 30\text{A}$ output drive at slew rates up to 1400A/s for 45mH corrector magnets. The internal control bandwidth is about 4 kHz.

The MCOR30 uses the same modular crate architecture as the PEP-II MCOR12 design [13]. Each MCOR30 module occupies two crate slots. The MCOR30 PWM switching control uses a volt-seconds current-mode control scheme [14] instead of the commercial voltage-mode modules used in the MCOR12. Feeding back the volt-seconds applied to the output filter circuit effectively removes the filter inductance pole from the compensation network. This dramatically increases the overall step response. Application of the volt-seconds on a pulse-by-pulse basis also considerably improves the attenuation of high frequency noise and ripple on the input DC mains.

An onboard VME processor/crate controller with an array of 24-bit Δ - Σ ADCs receives the fast orbit feedback correction data over a high speed digital link and generates corrected set-point values for the eight MCOR30s in each crate [15]. Maximum set-point update rates per MCOR30 channel are in the order of 1 kHz.

7 STABILITY ADJUSTMENTS

Specifications required the PS output voltage ripple to be less than 1000 ppm. Measurements conducted on one of the quadrupole PS have demonstrated that this requirement has been satisfied.

The PS current stability is provided by a proportional-integral compensation circuit through the Bitbus controller. Values for the gain and time constants were adjusted during the field testing phase. First, with the PS working as a voltage source, a frequency response graph was constructed to determine the load inductance (L_0). Load resistance (R_0) and the PS voltage loop gain are also determined during this phase. Depending upon the load values of L_0 and R_0 , the RC compensation network on the Bitbus controller is calculated and adjusted so as to provide a 3dB 10Hz bandwidth. To assure a critically damped response, the Bitbus controller R*C compensation time must equal the load time constant (L_0/R_0).

8 REFERENCES

- [1] <http://ssrl.slac.stanford.edu>
- [2] J. Safranek et al, "SPEAR 3 Commissioning" APAC'04, Gyeongju, Korea, March 2004.
- [3] <http://134.79.112.52:8080/pcd/>
- [4] <http://www.slac.stanford.edu>
- [5] <http://www.slac.stanford.edu/accel/pepii/home.html>
- [6] P. Bellomo et al, "B-Factory Intermediate DC Magnet Power Systems Reliability Modeling and Results", PAC 2001, Chicago, June 2001.
- [7] P. Bellomo et al, "Progress on PEP-II Magnet Power Conversion System", EPAC'96, Sitges, June 1996.
- [8] L.T. Jackson et al, "PEP-II Magnet Power Conversion Systems", PAC'95, Dallas, May 1995.
- [9] <http://www.bitbus.org/faq.htm>
- [10] P. Bellomo, "Intermediate Power Supply Performance Specification", Engineering Note SSRL M-379, Rev 1. SLAC internal publication. Sept, 2001.
- [11] P. Bellomo, "Large Power Supply Performance Specification", Engineering Note SSRL M-370, Rev 1. SLAC internal publication. June, 2001.
- [12] P. Bellomo, "Dipole Bulk Power Supply Performance Specification", Engineering Note SSRL M-354, Rev 0, SLAC internal publication, April 2002.
- [13] G. E. Leyh et al, "A Multi-Channel Corrector Magnet Controller", PAC'95, Dallas, May 1995.
- [14] G. E. Leyh, "MCOR 30 Technical Manual IM-444-640-00-R0", SLAC internal publication, June 2003.
- [15] E. Medvedko et al, "High Resolution Analog/Digital Power Supply Controller", PAC 2003, Portland, May 2003.